

# Feb 1963 onwards Norton Electra 400cc twin with aftermarket regulator/rectifier and Pazon Sure-Fire electronic ignition (updated)

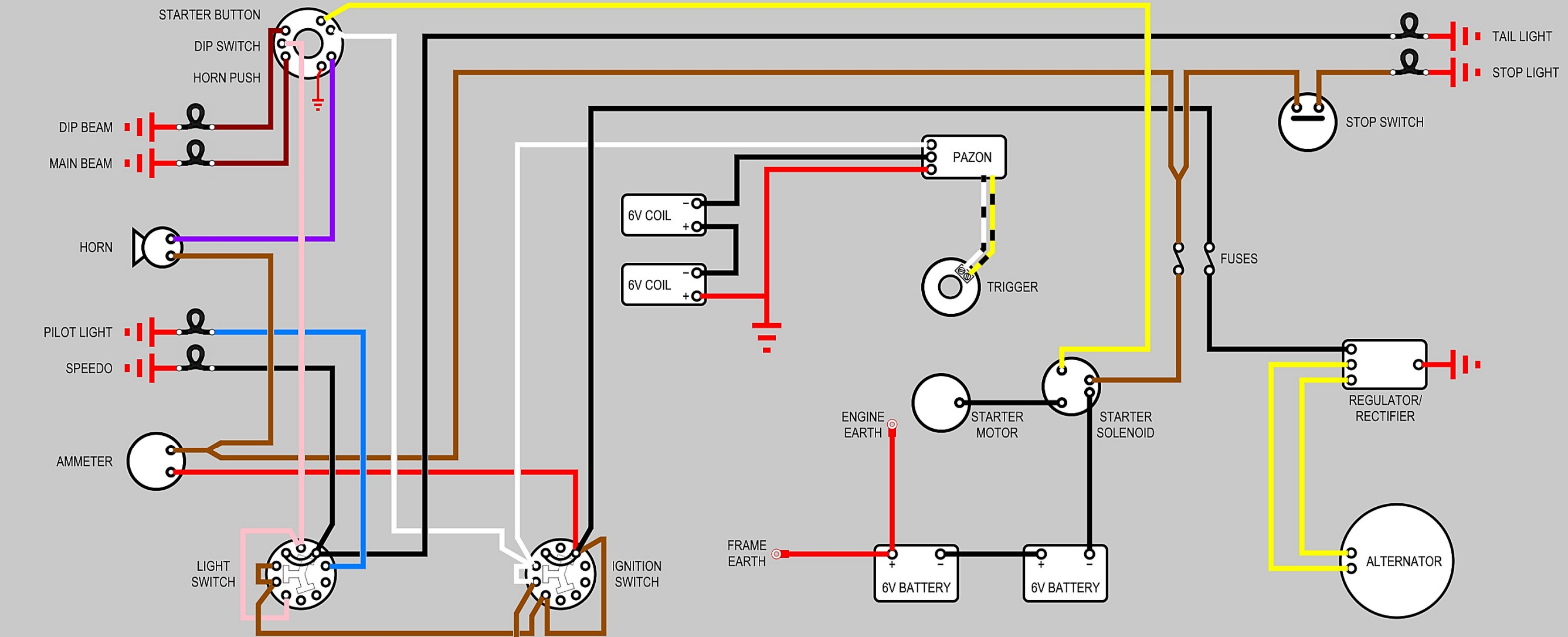

## COMMENTS

Removed factory 3-wire alternator stator, rectifier and regulator  
 Added 'Lucas type' 2-wire alternator stator and combined regulator / rectifier unit  
 Removed factory points, condensers and 12 volt coils  
 Added Pazon-Sure electronic ignition and 6 volt coils - note this requires that the coil wiring is changed from independently fired to series wired wasted spark  
 Note: Norton iterated on the original Wipac schematic - this rendition allows lighting to be used when the ignition switch is in the 'emergency' position

Black	Brown	Dark Red	Light Red	Dark Blue	Light Blue	Dark Green	Light Green	Yellow	Pink	White	Violet	Grey	Maroon	Orange
-------	-------	----------	-----------	-----------	------------	------------	-------------	--------	------	-------	--------	------	--------	--------

Standard wiring is Positive Earth - that is to say the RED (POSITIVE) cable goes FROM the battery TO the frame

Grant Tiller October 2023