

Feb 1963 onwards Norton Electra 400cc twin with aftermarket regulator/rectifier (updated)

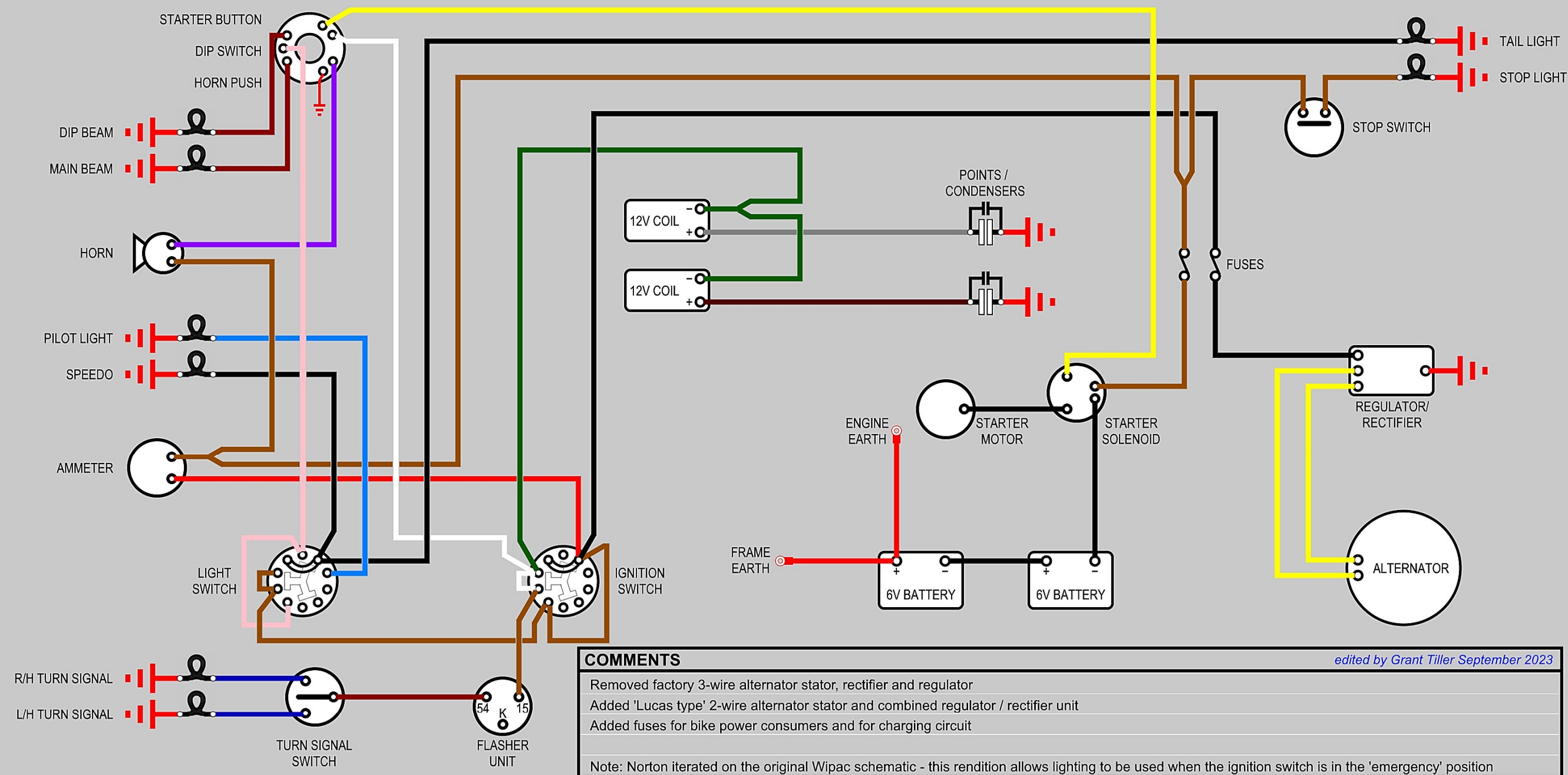

**COMMENTS**

*edited by Grant Tiller September 2023*

Removed factory 3-wire alternator stator, rectifier and regulator

Added 'Lucas type' 2-wire alternator stator and combined regulator / rectifier unit

Added fuses for bike power consumers and for charging circuit

Note: Norton iterated on the original Wipac schematic - this rendition allows lighting to be used when the ignition switch is in the 'emergency' position

Black

Brown

Dark Red

Light Red

Dark Blue

Light Blue

Dark Green

Light Green

Yellow

Pink

White

Violet

Grey

Maroon

Orange

Standard wiring is Positive Earth - that is to say the RED (POSITIVE) cable goes FROM the battery TO the frame