

Feb 1963 onwards Norton Electra 400cc twin with aftermarket regulator/rectifier

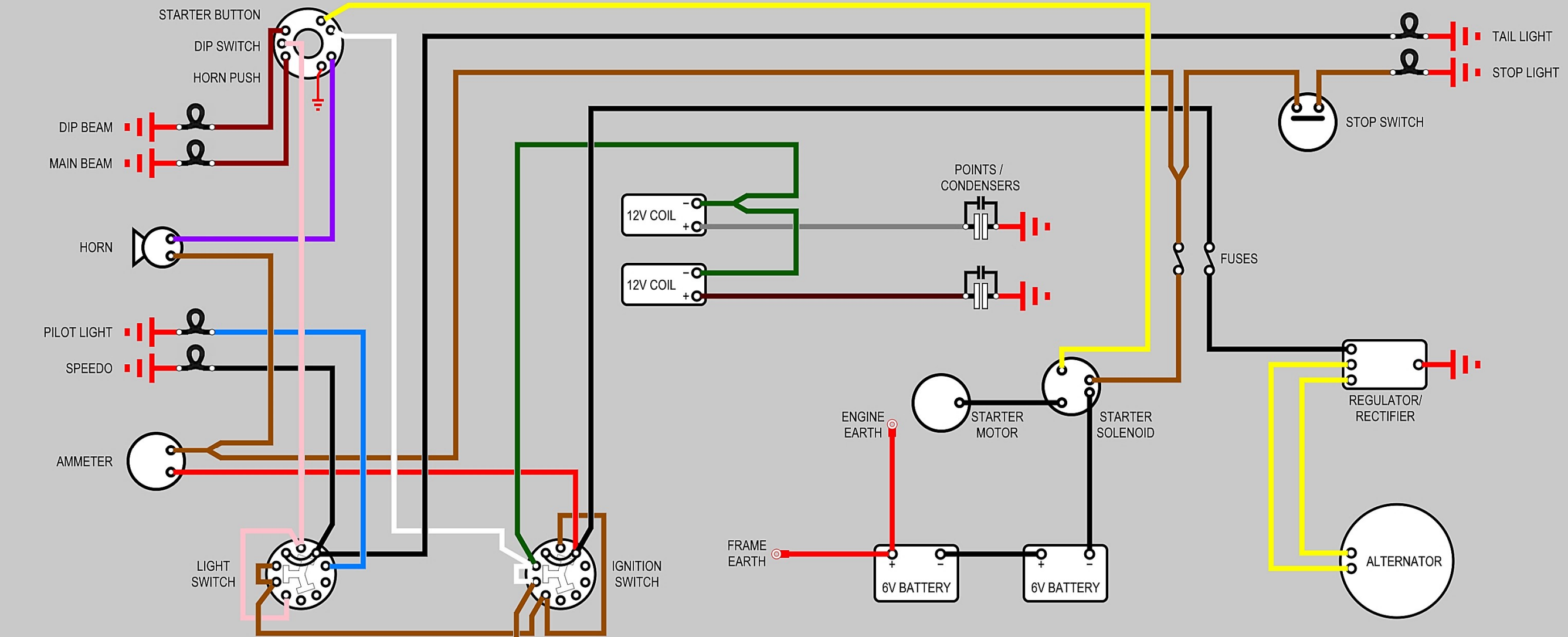

COMMENTS

Removed factory 3-wire alternator stator, rectifier and regulator
 Added 'Lucas type' 2-wire alternator stator and combined regulator / rectifier unit
 Added fuses for bike power consumers and for charging circuit

edited by Grant Tiller September 2023



Standard wiring is Positive Earth - that is to say the RED (POSITIVE) cable goes FROM the battery TO the frame