

Custom Norton Commando Wiring Diagram - Bob Bartholomew

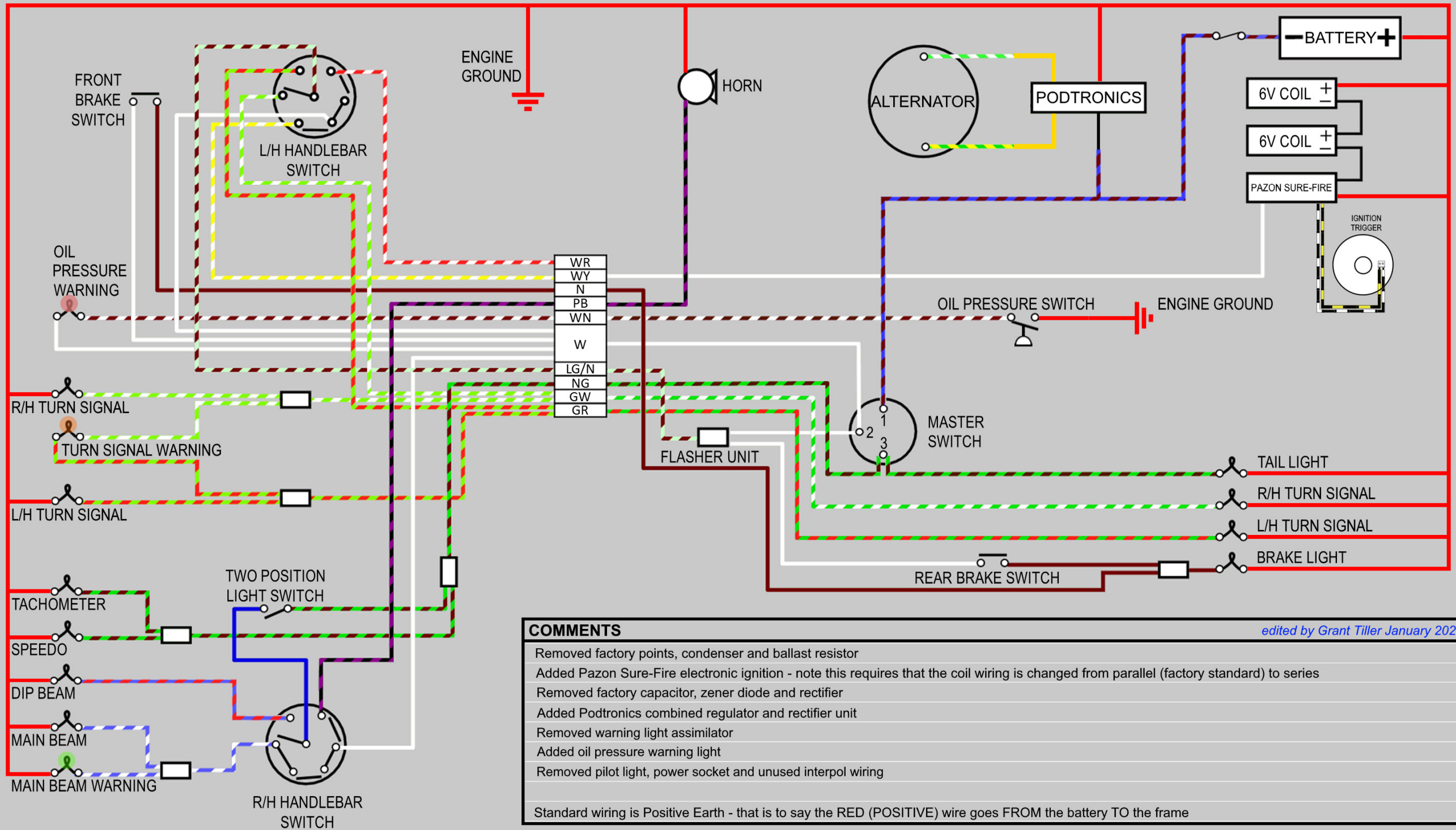

COMMENTS

edited by Grant Tiller January 2021

- Removed factory points, condenser and ballast resistor
 - Added Pazon Sure-Fire electronic ignition - note this requires that the coil wiring is changed from parallel (factory standard) to series
 - Removed factory capacitor, zener diode and rectifier
 - Added Podtronics combined regulator and rectifier unit
 - Removed warning light assimilator
 - Added oil pressure warning light
 - Removed pilot light, power socket and unused interpol wiring
- Standard wiring is Positive Earth - that is to say the RED (POSITIVE) wire goes FROM the battery TO the frame